

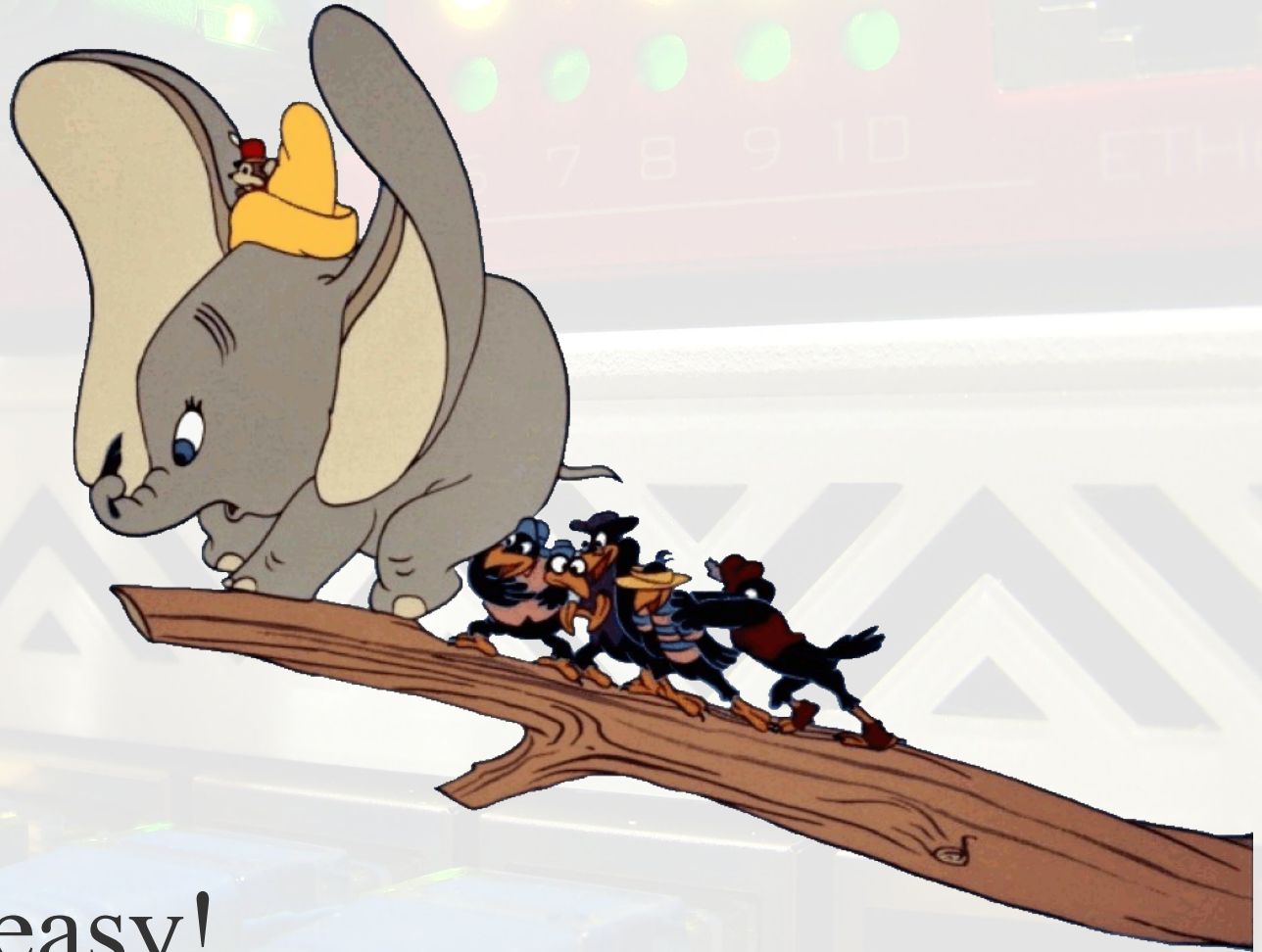

Switch your RouterBoard

- Daniel Starnowski
- 

Switch chip on MikroTik RouterBoard



- It is really easy!

RouterBoard – just an example

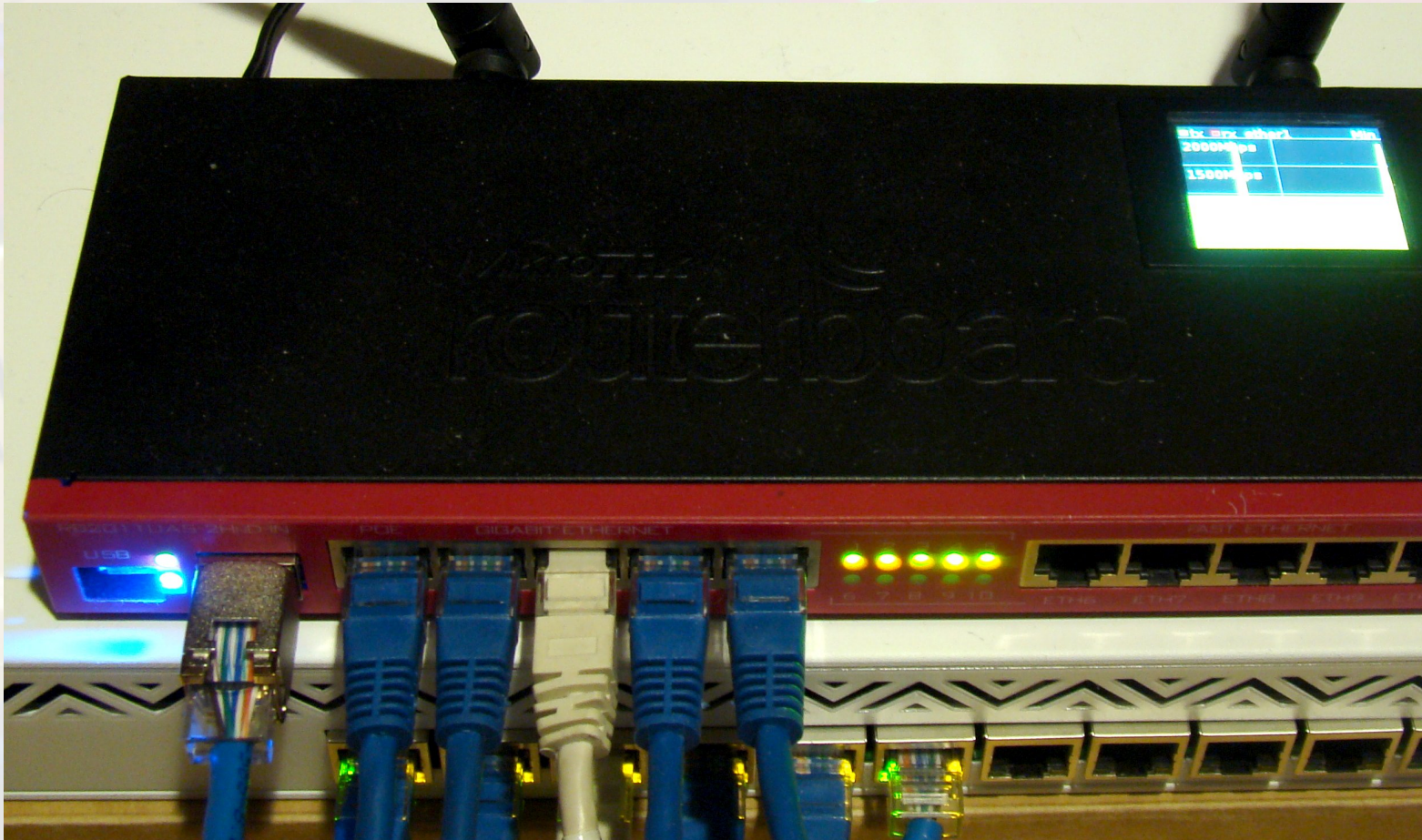

OSI layers

- **Switch** operates on layer 2 and forwards ethernet frames between ports
- **Router** operates on layer 3 and forwards IP packets decapsulating them from frames

MAC header

IP header

Layer 4 + data

CRC

RouterBoard – the anatomy

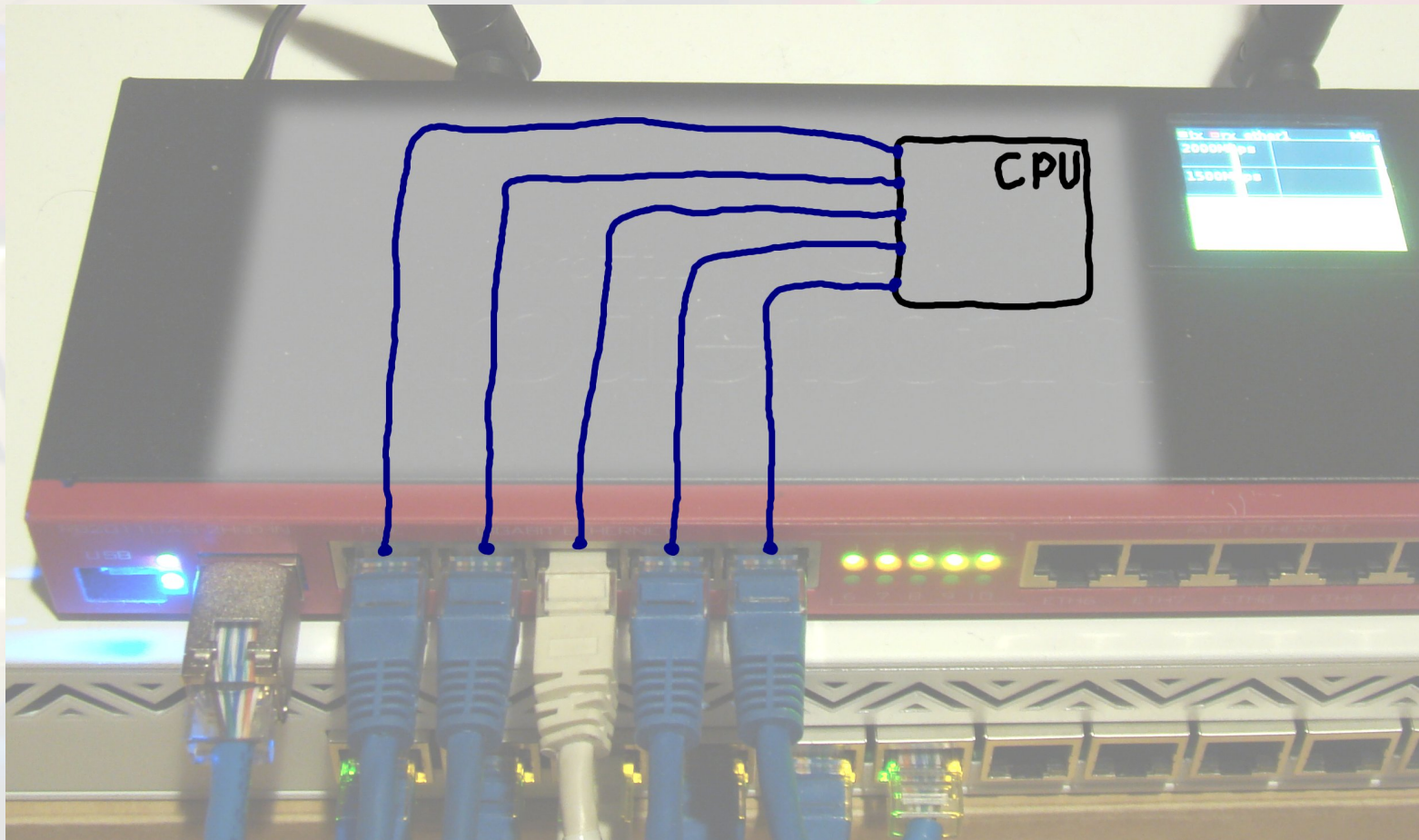

RouterBoard – ports and interfaces

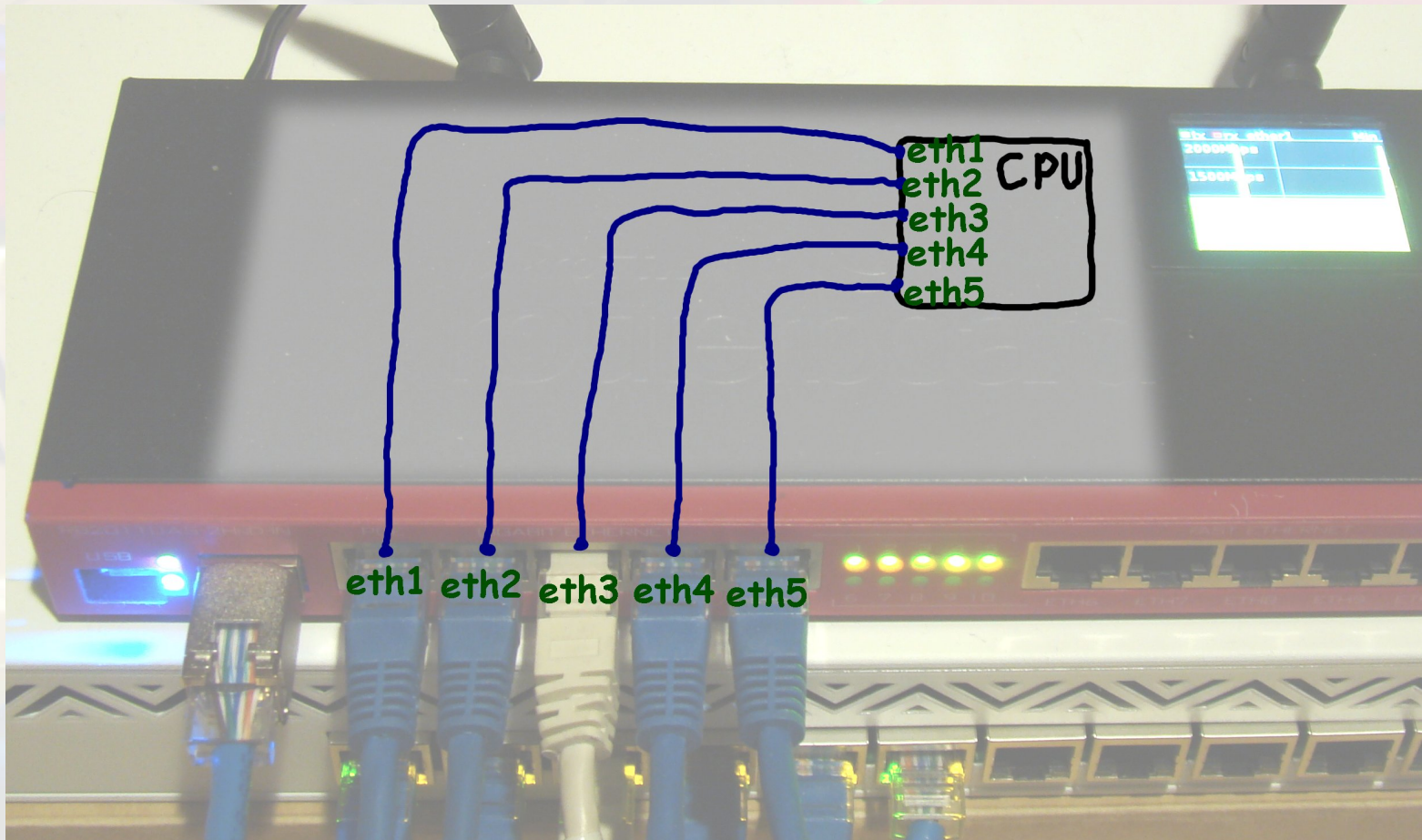

RouterBoard – a routing scenario

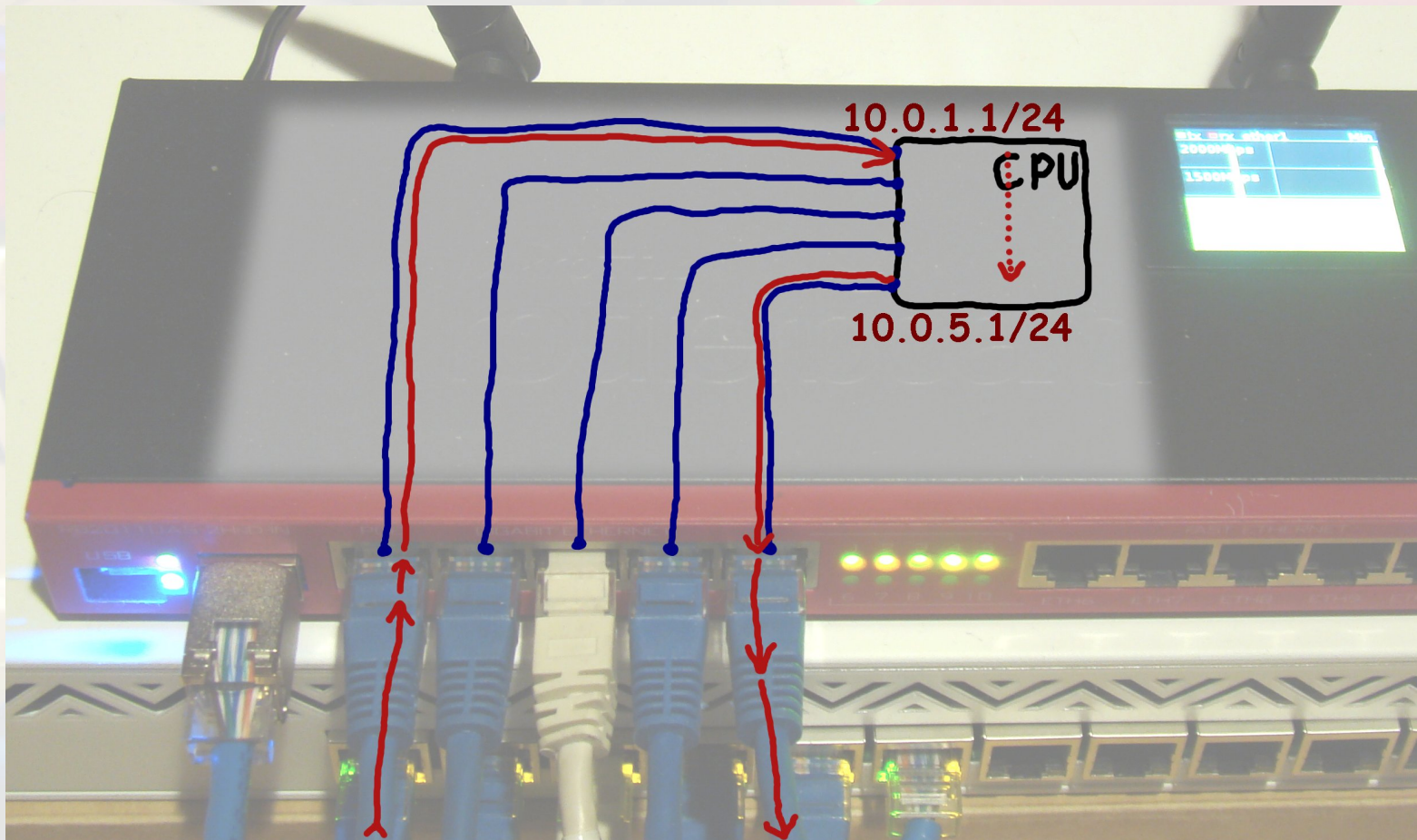

RouterBoard – a bridge

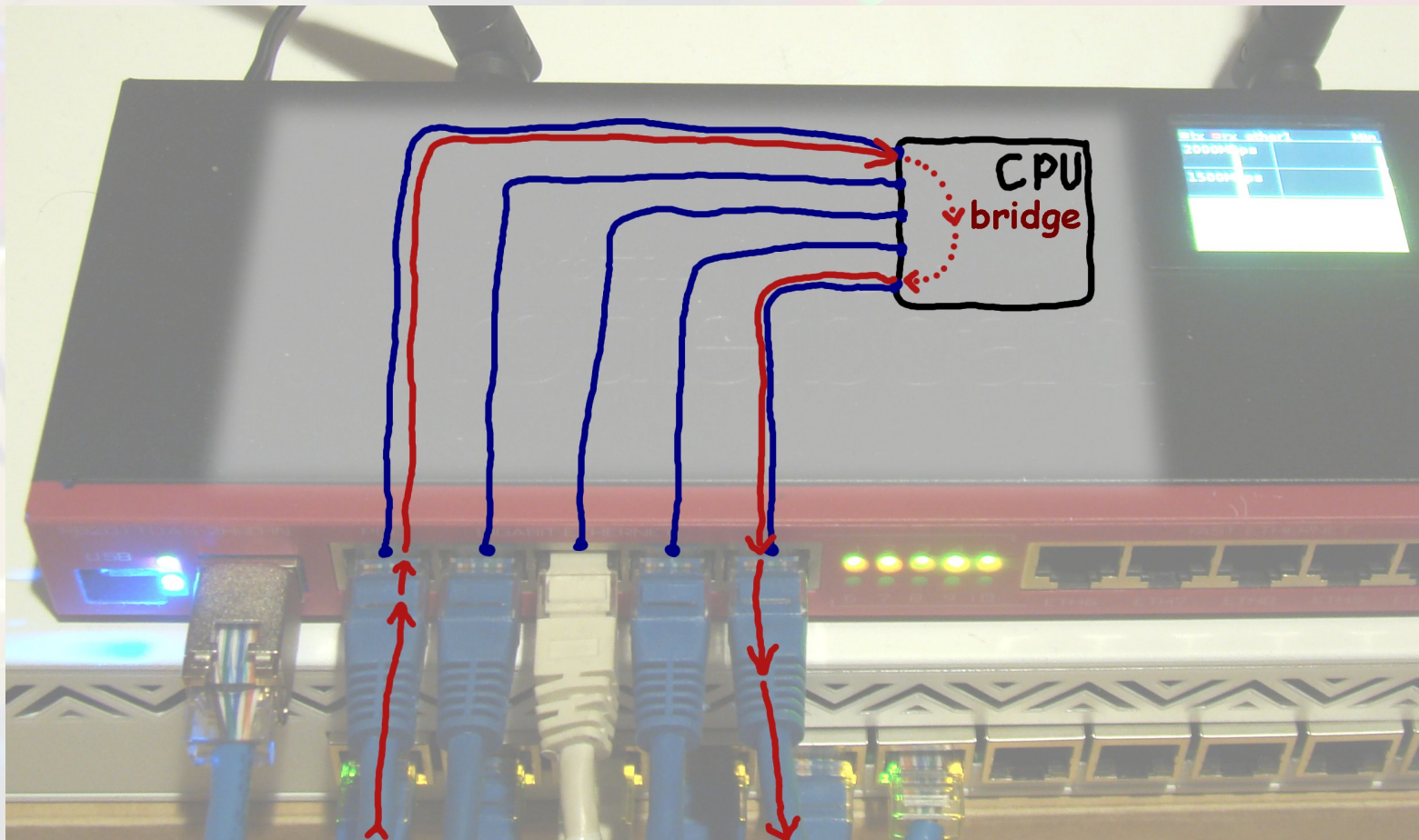

RouterBoard – IP address on a bridge

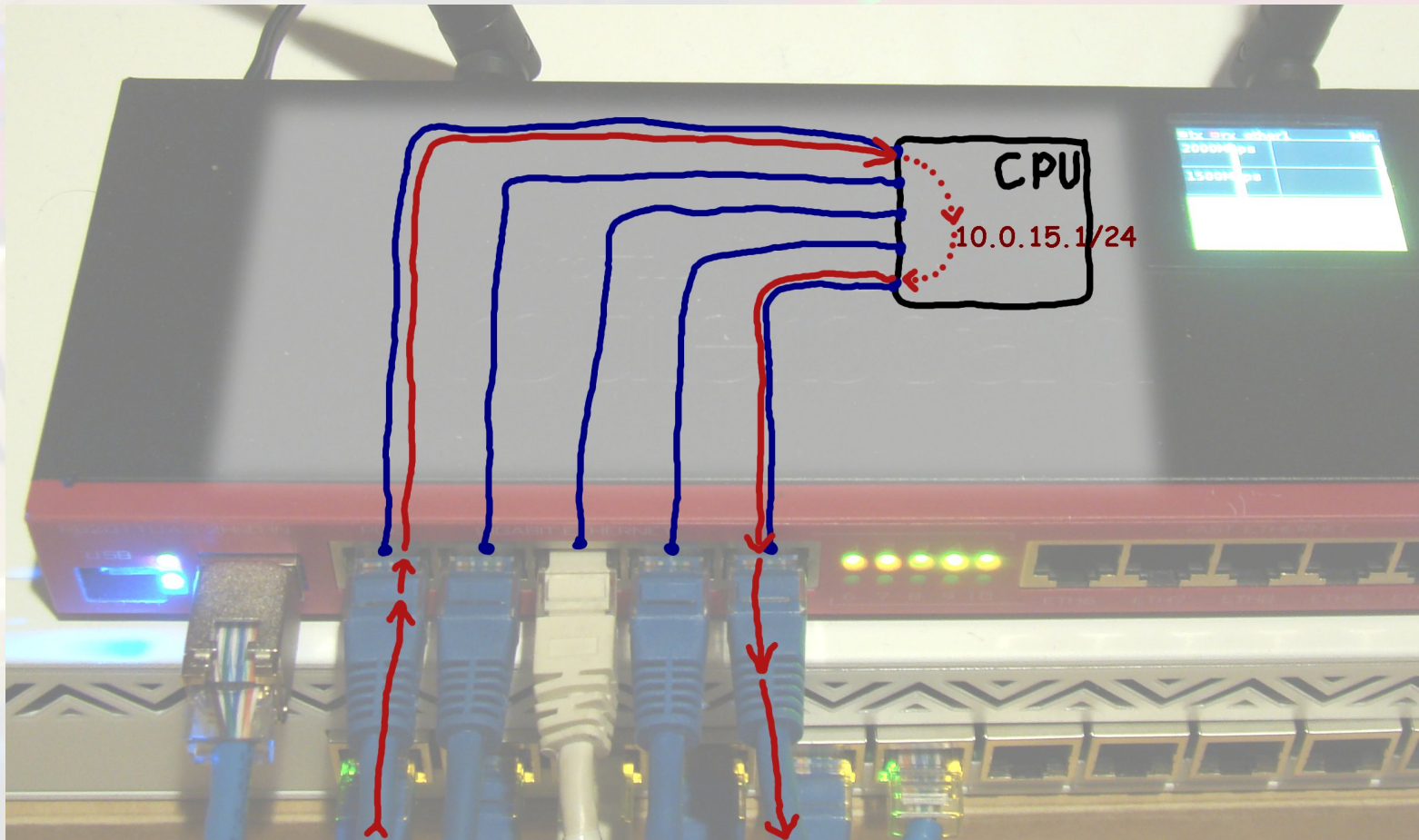

RB2011 – the performance

- fast path:
 - ~1500 Mbps with 1500 B packets
 - ~150 Mbps with 64 B packets
- without fast path:
 - ~1000 Mbps with 1500 B packets
 - ~50 Mbps with 64 B packets

RouterBoard – VLAN bridging

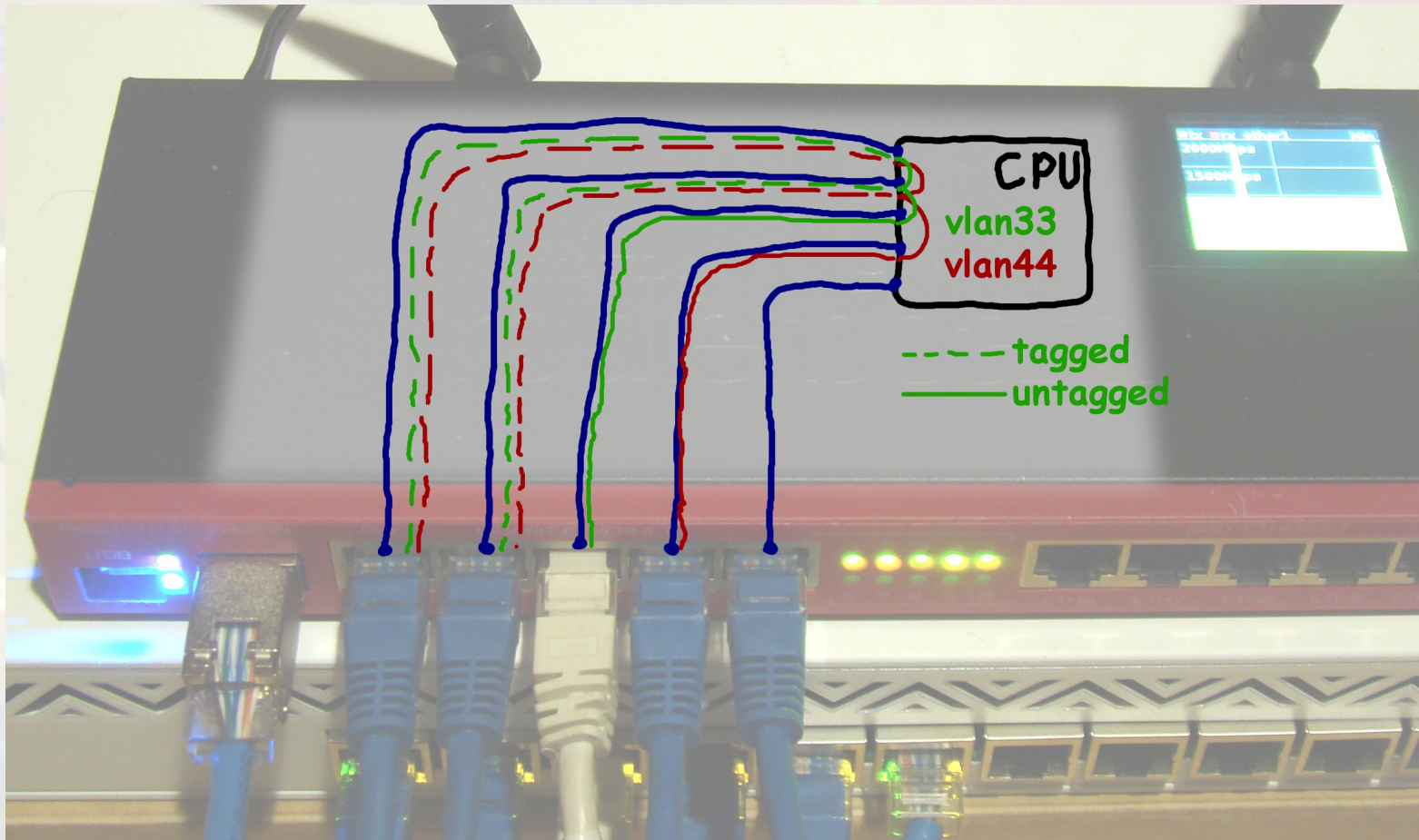

RouterBoard – VLAN bridging config

- Create VLAN **vlan33eth1** with tag 33 on interface ether1
- Create VLAN **vlan33eth2** on ether2
- Create bridge **vlan33**
- Add ports **vlan33eth1**, **vlan33eth2** and **ether3** to the bridge **vlan33**

RB2011 – VLAN bridging test

- 8 different streams
- Only 1500 B packets
- 8 x 122 Mbps – 1% packet loss
(total 976 Mbps)
- 8 x 60 Mbps – 0,1% packet loss
(total **480 Mbps**)

The answer – the switch chip

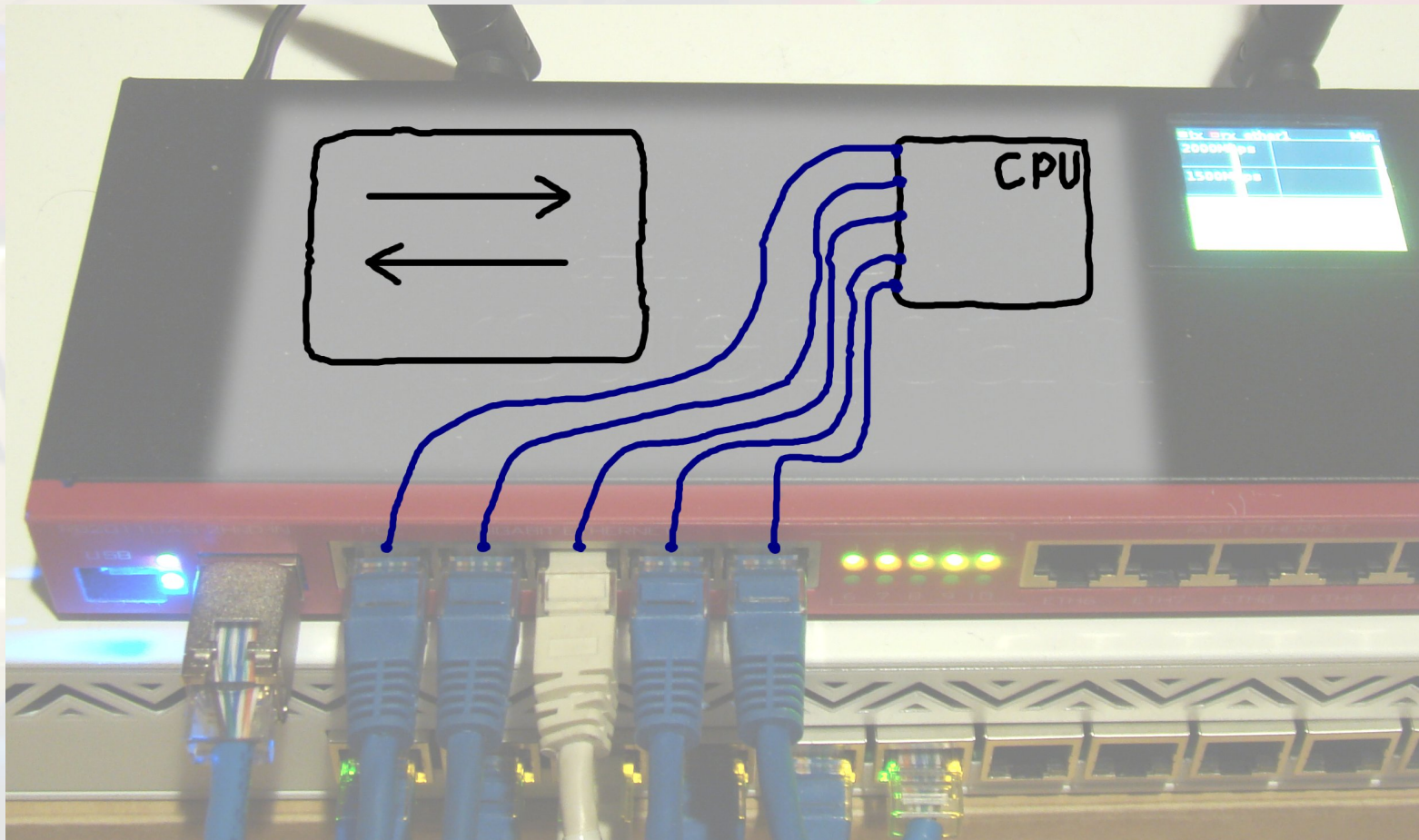

The switch chip

- Almost every new RouterBoard with multiple ethernet interfaces is equipped with a switch chip
- Hardware switch without using CPU
- From ROS v6 – VLAN trunking is possible

Switch chips in MikroTik devices

- Atheros 8316
- Atheros 8327
- Atheros 8227
- Atheros 7240
- other

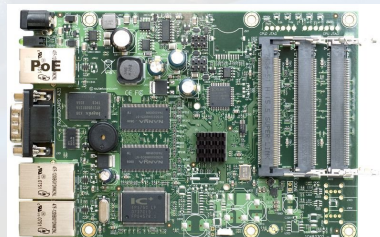

What chip does my RouterBoard have?

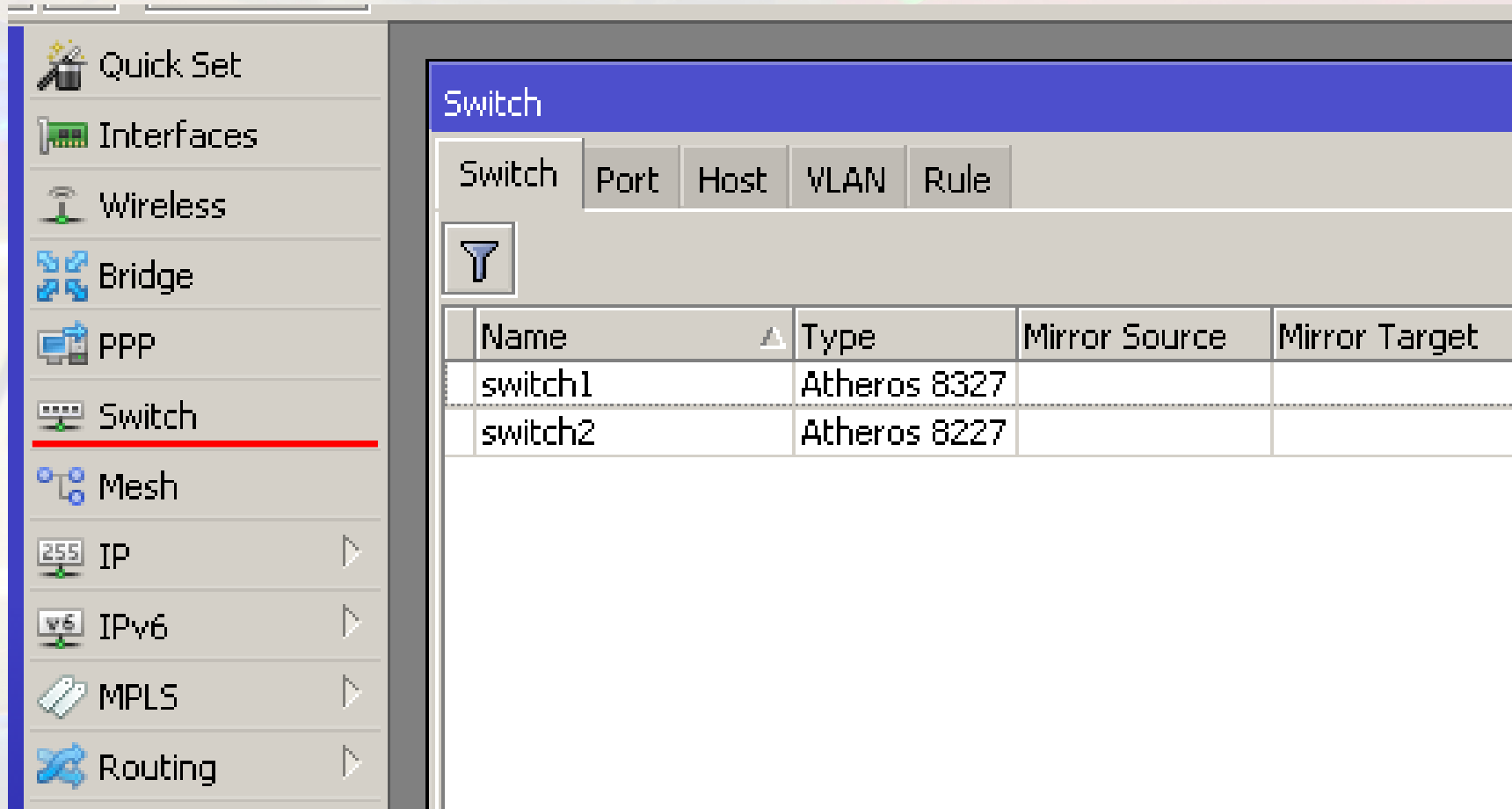

The screenshot displays the Mikrotik WinBox interface. On the left, a sidebar contains a list of network features: Quick Set, Interfaces, Wireless, Bridge, PPP, Switch (highlighted with a red line), Mesh, IP, IPv6, MPLS, and Routing. The main window shows the 'Switch' configuration page, which includes tabs for 'Switch', 'Port', 'Host', 'VLAN', and 'Rule'. Below the tabs is a filter icon and a table listing the configured switches.

Name	Type	Mirror Source	Mirror Target
switch1	Atheros 8327		
switch2	Atheros 8227		

How to turn the switch chip on?

The screenshot shows a network configuration interface with a sidebar on the left and a main panel on the right. The sidebar contains various configuration categories: Quick Set, Interfaces (highlighted with a red line), Wireless, Bridge, PPP, Switch, Mesh, IP, IPv6, MPLS, Routing, System, and Queues. The main panel is titled 'Interface List' and has several tabs: Interface, Ethernet (selected), EoIP Tunnel, IP Tunnel, GRE Tunnel, VLAN, VRRP, Bonding, and LTE. Below the tabs are several icons: a checkmark, a red X, a yellow folder, a funnel, and a mouse cursor. The main area contains a table with the following columns: Name, Type, L2 MTU, Master Port, Switch, and PoE. The 'Switch' column is highlighted in red. The table lists 11 interfaces, all of type 'Ethernet', with L2 MTU of 1598. The 'Master Port' column contains 'none' for all. The 'Switch' column contains 'switch1' for ether1-5 and sfp1, and 'switch2' for ether6-10.

	Name	Type	L2 MTU	Master Port	Switch	PoE
R	ether1	Ethernet	1598	none	switch1	
R	ether2	Ethernet	1598	none	switch1	
R	ether3	Ethernet	1598	none	switch1	
R	ether4	Ethernet	1598	none	switch1	
R	ether5	Ethernet	1598	none	switch1	
RS	ether6	Ethernet	1598	none	switch2	
RS	ether7	Ethernet	1598	none	switch2	
RS	ether8	Ethernet	1598	none	switch2	
S	ether9	Ethernet	1598	none	switch2	
S	ether10	Ethernet	1598	none	switch2	
	sfp1	Ethernet	1598	none	switch1	

How to turn the switch chip on?

The screenshot displays a network configuration tool. On the left, the 'Interface List' window shows a table of interfaces. The 'Ethernet' tab is selected. The table lists interfaces ether1 through ether10 and sfp1, all of type 'Ethernet'. ether2 is selected. Below the table, it says '11 items out of 16 (1 selected)'. On the right, the 'Interface <ether2>' configuration window is open. It has tabs for 'General', 'Ethernet', 'Status', and 'Overall Stats'. The 'Ethernet' tab is active. Fields include Name (ether2), Type (Ethernet), MTU (1500), L2 MTU (1598), Max L2 MTU (4074), MAC Address (D4:CA:6D:96:DC:B7), and ARP (enabled). The 'Master Port' dropdown is open, showing a list of options: ether1, ether2, ether3, ether4, ether5, ether6, ether7, ether8, ether9, ether10, none, and sfp1. A mouse cursor is pointing at ether1. On the far right, there are buttons for OK, Cancel, Apply, Disable, Comment, Torch, Blink, Reset MAC Address, and Reset Counters.

Interface	Name	Type
R	ether1	Ethernet
R	ether2	Ethernet
R	ether3	Ethernet
R	ether4	Ethernet
R	ether5	Ethernet
RS	ether6	Ethernet
RS	ether7	Ethernet
RS	ether8	Ethernet
S	ether9	Ethernet
S	ether10	Ethernet
	sfp1	Ethernet

11 items out of 16 (1 selected)

Interface <ether2>

General | **Ethernet** | Status | Overall Stats | ...

Name: ether2

Type: Ethernet

MTU: 1500

L2 MTU: 1598

Max L2 MTU: 4074

MAC Address: D4:CA:6D:96:DC:B7

ARP: enabled

Master Port: none

Bandwidth (Rx/Tx):

Switch:

- ether1
- ether2
- ether3
- ether4
- ether5
- ether6
- ether7
- ether8
- ether9
- ether10
- none
- sfp1

OK

Cancel

Apply

Disable

Comment

Torch

Blink

Reset MAC Address

Reset Counters

Activating the switch chip

- If we set „master port“ on ether2 to „ether1“, we will activate the switch chip.
- How many ports will be active on the chip?

Connections without using the chip

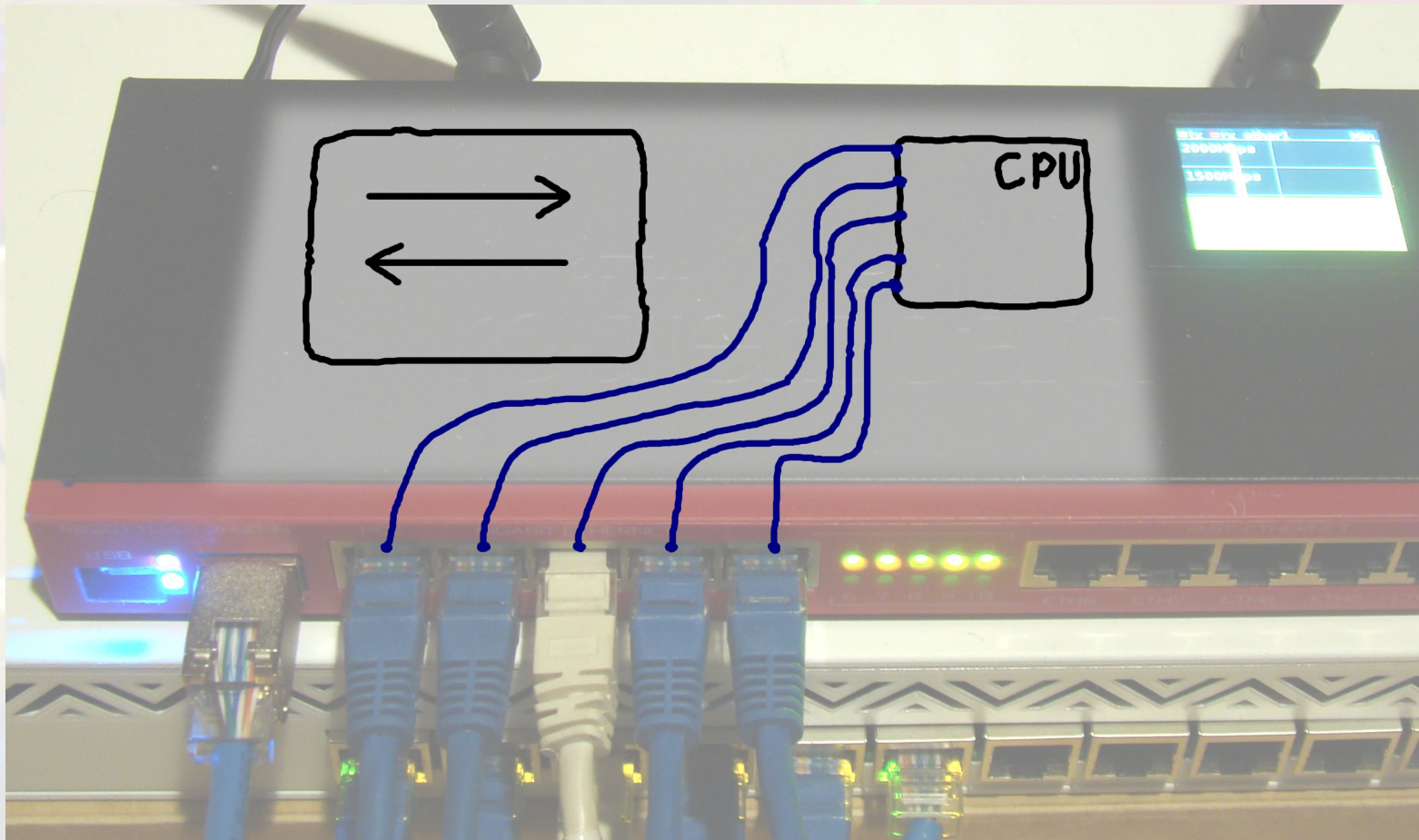

Activating the switch chip

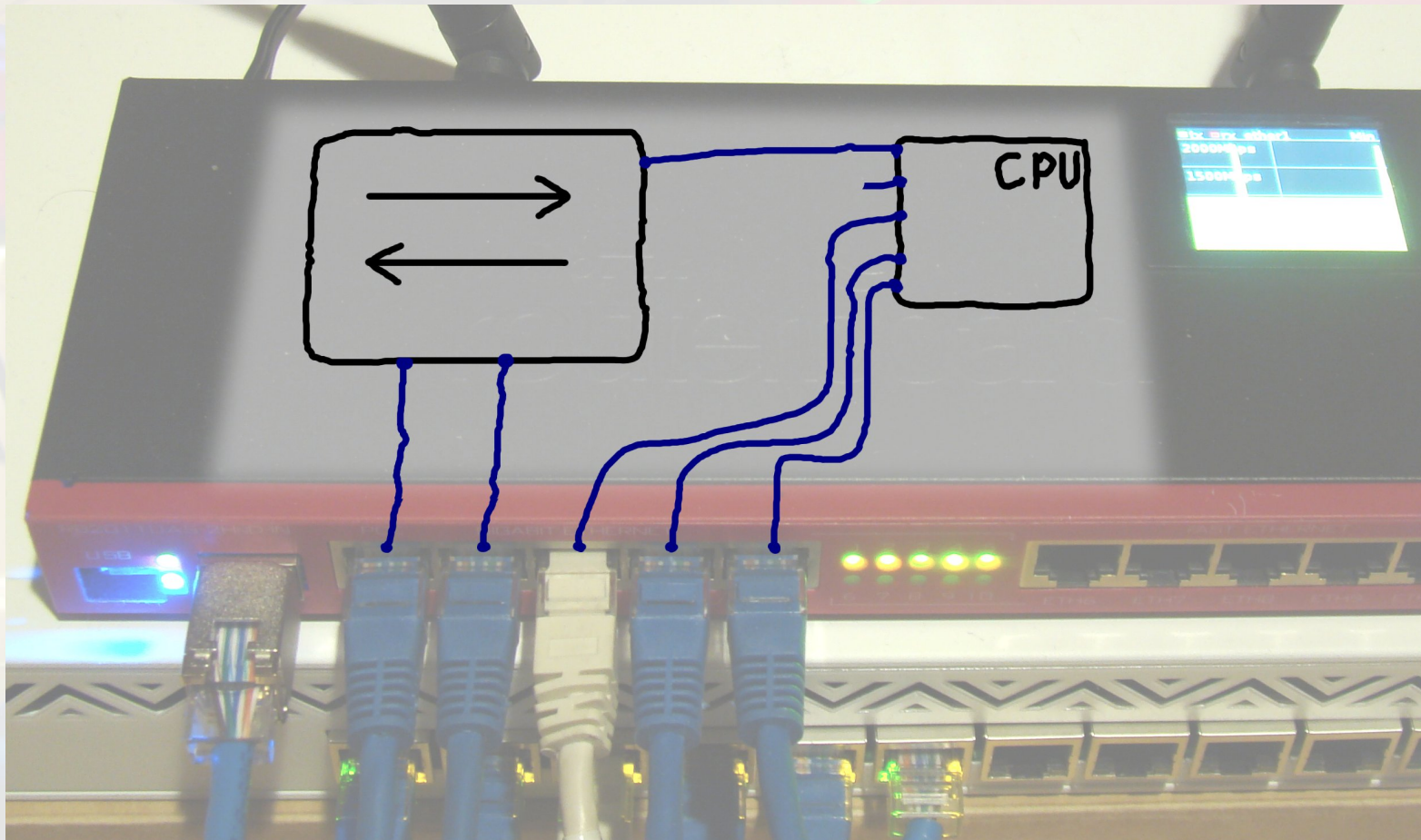

Switch chip – the master port

- Master port – only in the same chip
- Only 1 master port possible for a chip
- The master and „slave“ ports are equal for the switch chip
- Only one difference – the interface, the chip will be visible on

Switch chip – port names

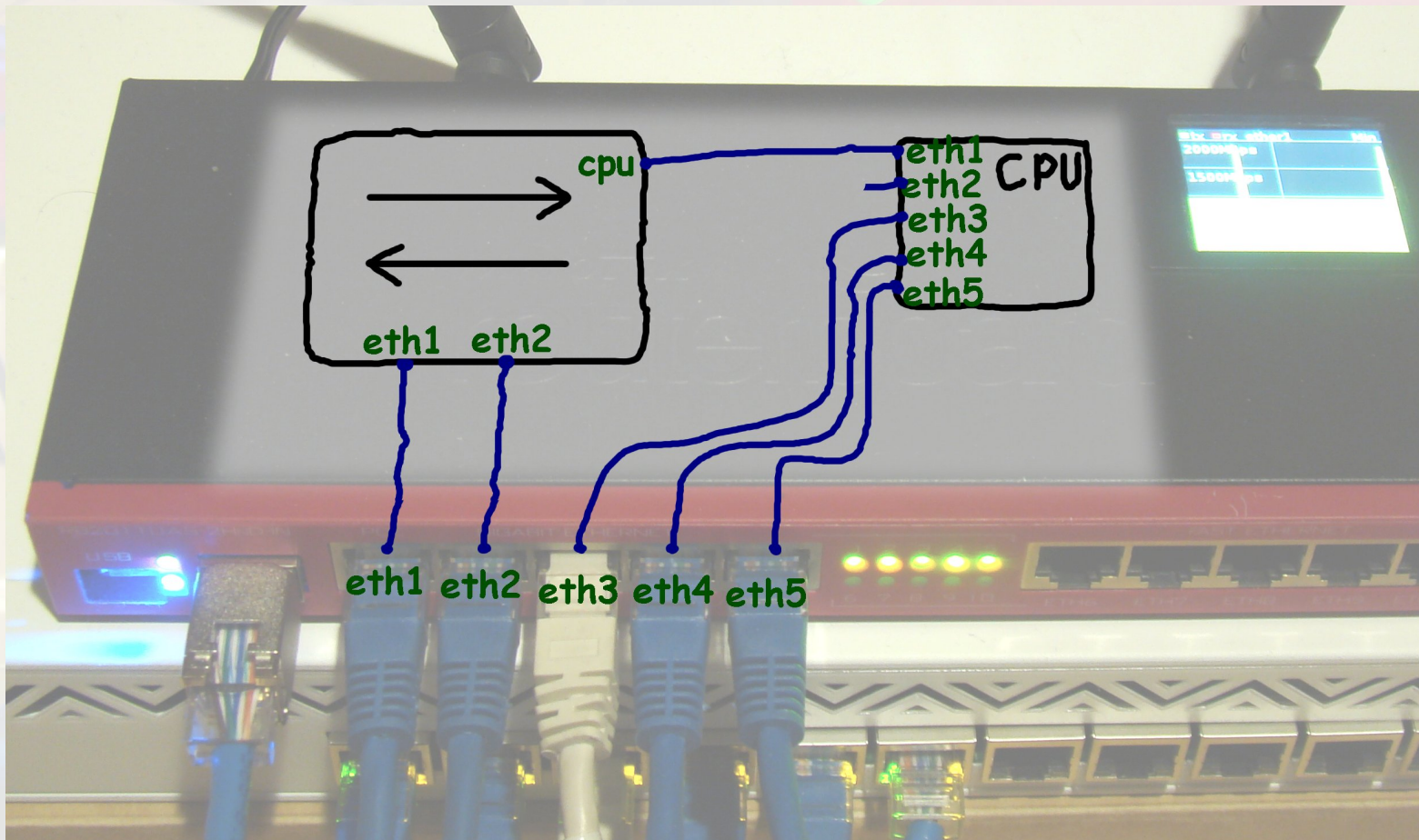

Switch chip – port names

- The same names:
 - **interfaces** seen from the CPU
(ether1, ether2, ...)
 - **physical ports** seen from the chip
(ether1, ether2, ...)
- Only one connection between the chip
(the cpu port) and the CPU (master port)

Default configuration of switch chip

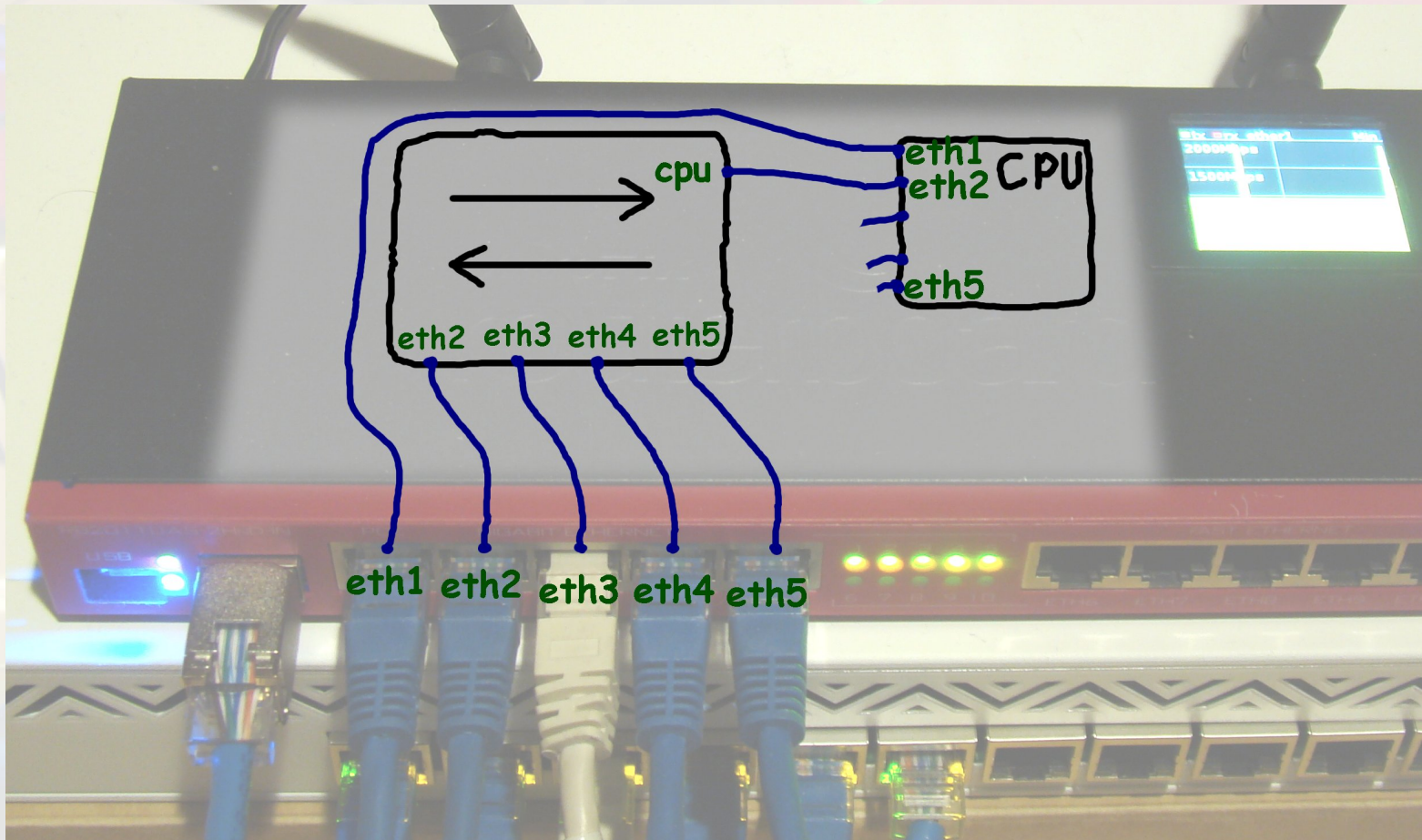

Default configuration of switch chip

- In RouterBoards like 2011 or 951
- ether1 – gateway port (not included in the switch group)
- ether2-ether5 – switched ports
- ether2 – master port, used when configuring IP address, bridge, etc.

VLAN bridging – the software version

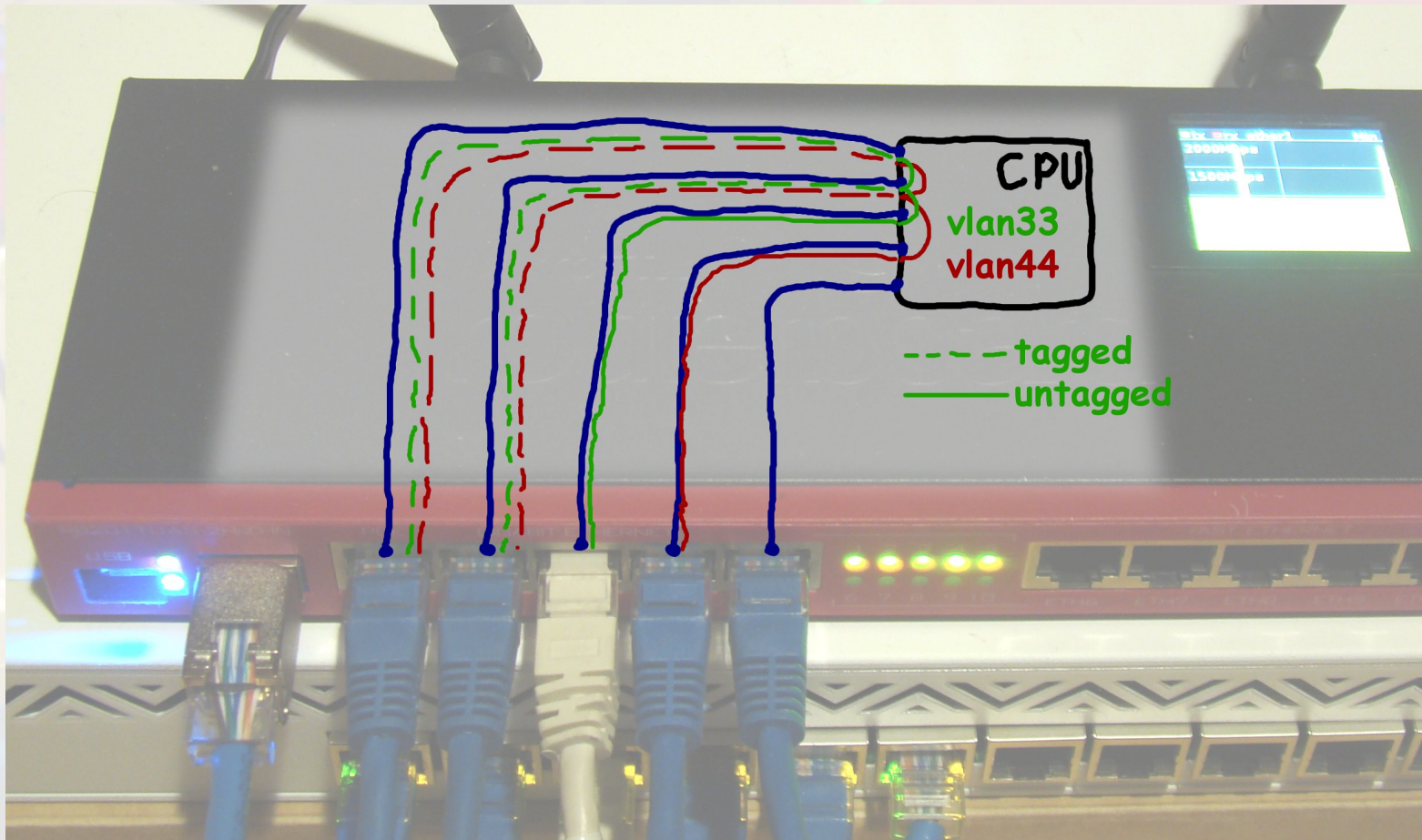

VLAN bridging with the switch chip

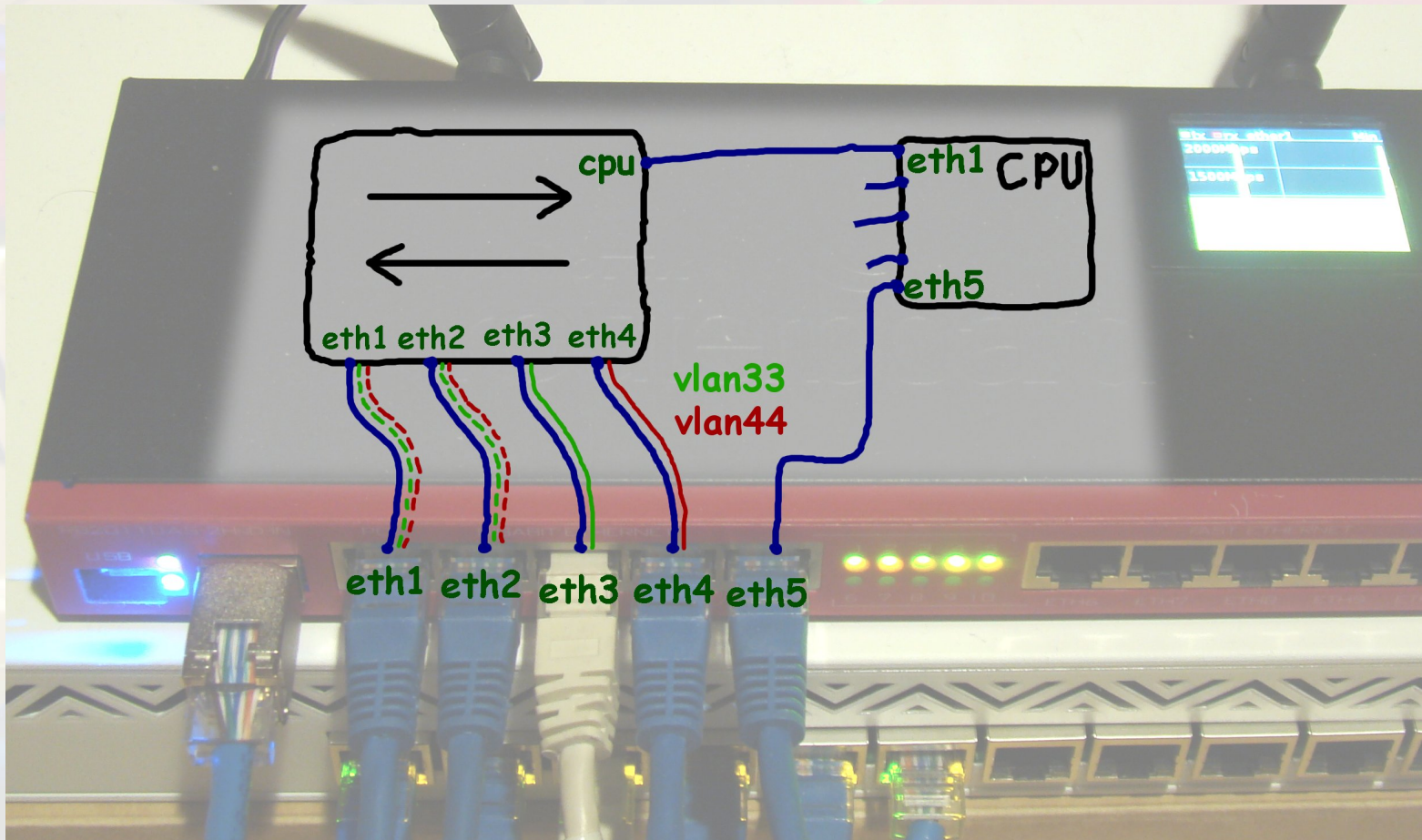

Switch chip – preparing the vlans

The screenshot shows a network configuration interface for a switch. The main window has tabs for 'Switch', 'Port', 'Host', 'VLAN', and 'Rule'. The 'VLAN' tab is selected. Below the tabs is a toolbar with icons for adding (+), removing (-), saving (checkmark), deleting (X), and filtering (funnel). A table lists existing VLANs:

Switch	VLAN ID	Ports
switch1	33	ether1, ether2, ether3

A 'New Switch VLAN' dialog box is open, showing the following configuration:

- Switch: switch1
- VLAN ID: 44
- Ports: ether1, ether2, ether4
- Independent Learning
- enabled

Buttons on the right side of the dialog include OK, Cancel, Apply, Disable, Copy, and Remove.

Switch chip – preparing the vlans

- Vlan settings not important as long as **VLAN Mode is disabled** (default)
- Independent learning – when some MACs can be visible on different ports in different vlans
 - Keeps separate table for the VLAN

Switch chip – the trunk port

The screenshot displays a network management interface with a 'Switch' window. The 'Port' tab is selected, showing a table of switch ports. The 'ether1' port is selected, and a 'Switch Port <ether1>' dialog box is open, showing configuration options for this port. The dialog box has fields for Name, Switch, VLAN Mode, VLAN Header, and Default VLAN ID. The 'VLAN Mode' is set to 'secure' and the 'VLAN Header' dropdown menu is open, showing options: 'add if missing', 'always strip', and 'leave as is'.

Name	Switch	VLAN Mode	VLAN Header	Default VLAN ID
ether1	switch1	disabled	leave as is	
ether2	switch1	disabled	leave as is	
ether3	switch1	disabled	leave as is	
ether4	switch1	disabled	leave as is	
ether5	switch1	disabled	leave as is	
<i>sfp1-gateway</i>	switch1	disabled	leave as is	
switch1 cpu	switch1	disabled	leave as is	
ether10	switch2	disabled	leave as is	
<i>ether6</i>	switch2	disabled	leave as is	
<i>ether7</i>	switch2	disabled	leave as is	
<i>ether8</i>	switch2	disabled	leave as is	
<i>ether9</i>	switch2	disabled	leave as is	
switch2 cpu	switch2	disabled	leave as is	

13 items (1 selected)

Switch Port <ether1>

Name: ether1

Switch: switch1

VLAN Mode: secure

VLAN Header: add if missing

Default VLAN ID: always strip

leave as is

Switch chip – the access port

The screenshot shows a network management interface with a 'Switch' window. The 'Port' tab is selected, displaying a table of switch ports. The 'ether3' port is selected, and a dialog box titled 'Switch Port <ether3>' is open, showing its configuration details.

Name	Switch	VLAN Mode	VLAN Header	Default VLAN ID
ether1	switch1	secure	add if missing	
ether2	switch1	secure	add if missing	
ether3	switch1	secure	always strip	44
ether4	switch1	secure	always strip	44
ether5	switch1	disabled	leave as is	
<i>sfp1-gateway</i>	switch1	disabled	leave as is	
switch1 cpu	switch1	disabled	leave as is	
ether10	switch2	disabled	leave as is	
<i>ether6</i>	switch2	disabled	leave as is	
<i>ether7</i>	switch2	disabled	leave as is	
<i>ether8</i>	switch2	disabled	leave as is	
<i>ether9</i>	switch2	disabled	leave as is	
switch2 cpu	switch2	disabled	leave as is	

Dialog Box: Switch Port <ether3>

Name: ether3
Switch: switch1
VLAN Mode: secure
VLAN Header: always strip
Default VLAN ID: 33

Buttons: OK, Cancel, Apply

13 items (1 selected)

Switch chip – trunk and access ports

- Trunk port:
 - Mode: **secure**
 - Header: **add if missing**
- Access port:
 - Mode: **secure**
 - Header: **always strip**
 - Default VLAN ID (a.k.a. PVID)
- No „hybrid“ ports!

Switch chip – the speed test

Uptime: 1d 05:02:51 CPU: 8% Hide Pas

Interface List

Interface Ethernet EoIP Tunnel IP Tunnel GRE Tunnel VLAN VRRP Bonding LTE



	Name	Type	L2 MTU	Tx	Rx	Tx Packet (p/s)	Rx Packet (p/s)
R	bridge-local	Bridge	1598	0 bps	0 bps	0	0
R	ether1	Ethernet	1598	960.3 Mbps	961.3 Mbps	82 333	82 418
RS	ether2	Ethernet	1598	960.4 Mbps	960.6 Mbps	82 346	82 360
RS	ether3	Ethernet	1598	958.2 Mbps	958.2 Mbps	82 383	82 378
RS	ether4	Ethernet	1598	958.1 Mbps	957.6 Mbps	82 371	82 330
R	ether5	Ethernet	1598	0 bps	0 bps	0	0
RS	ether6	Ethernet	1598	0 bps	0 bps	0	0
RS	ether7	Ethernet	1598	0 bps	0 bps	0	0
RS	ether8	Ethernet	1598	0 bps	0 bps	0	0
S	ether9	Ethernet	1598	0 bps	0 bps	0	0
S	ether10	Ethernet	1598	0 bps	0 bps	0	0
S	sfpl	Ethernet	1598	0 bps	0 bps	0	0
R	wlan1	Wireless (Atheros AR...	2290	109.5 kbps	7.9 kbps	11	13

Switch chip – the speed test

- With bridging – more than 0.1% loss visible with $8 * 60 = 480$ Mbps (and CPU $\sim 50\%$)
- Switch chip – almost no loss with $8 * 490$ Mbps = **3920 Mbps** (4 ports **wire speed**), CPU unchanged
- From ROS 6.5 – port stats available

Switch chip

– port stats

- From ROS 6.5 stats available for the switch ports (traffic doesn't need to go through CPU)

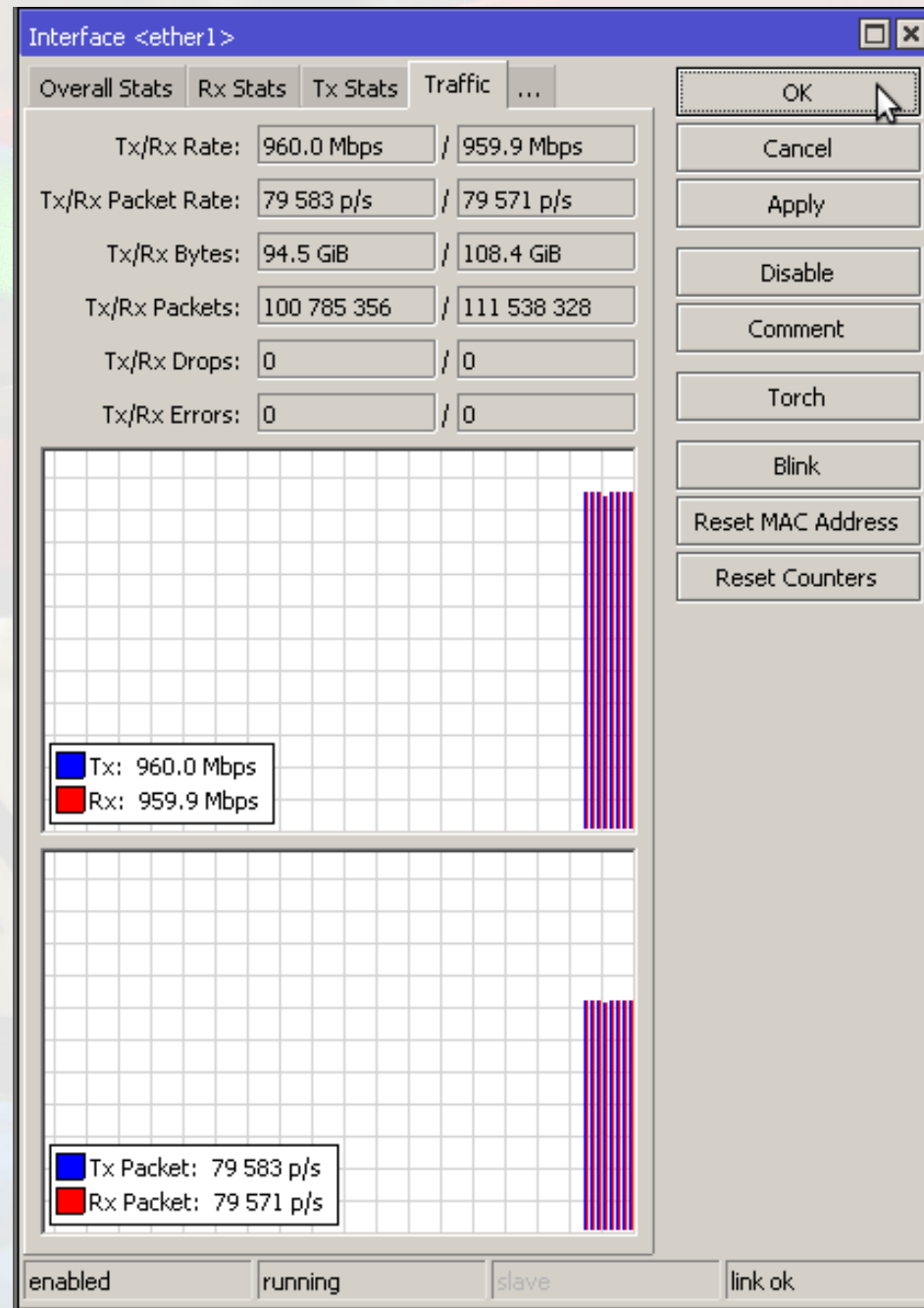

Switch chip – routing the VLANs

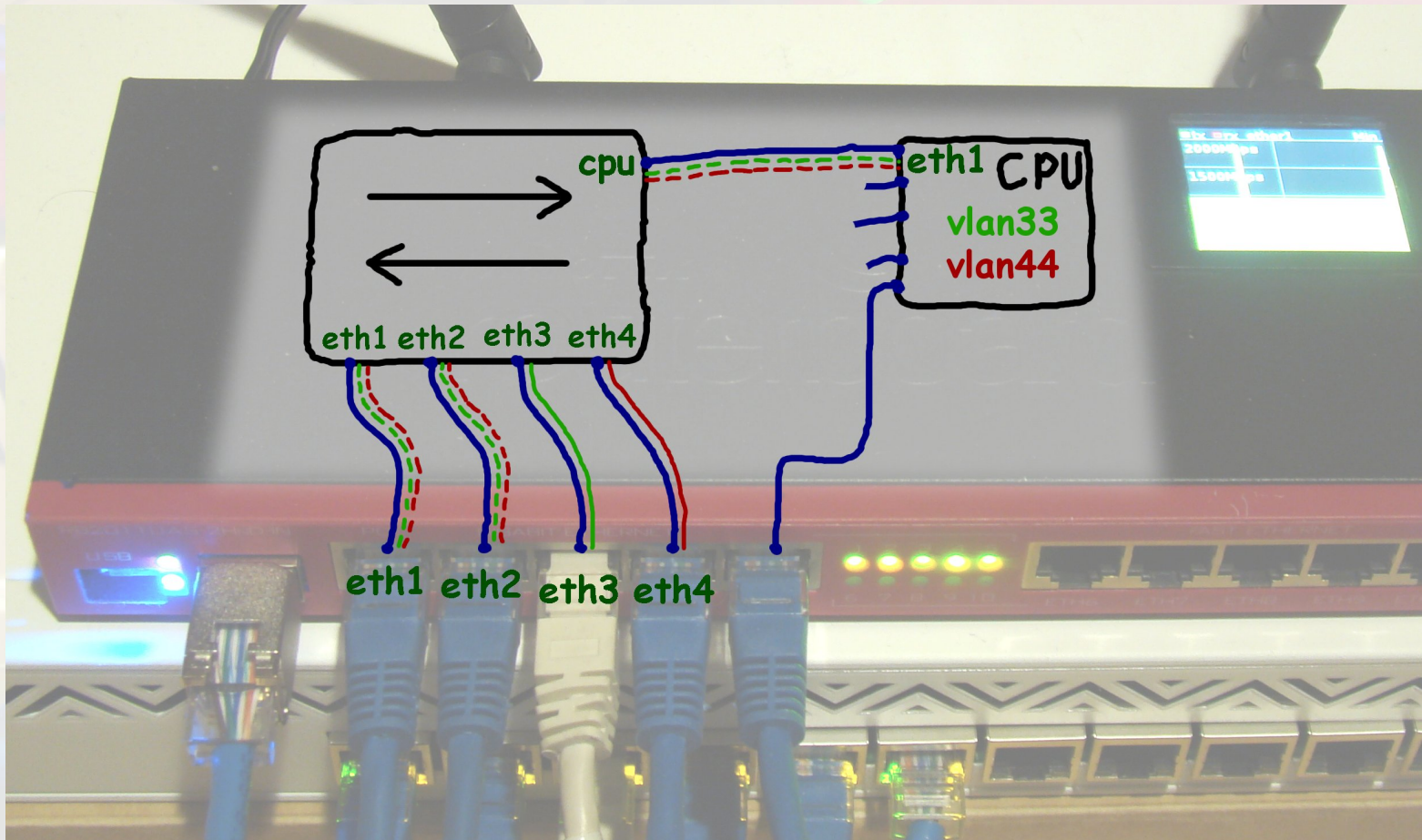

Switch chip – routing the VLANs

- Include **cpu** in selected VLANs configuration on the switch chip
- Change VLAN Mode to **secure** (header can be **leave as is**)
- Add VLAN interfaces on the master port (in the example – ether1)

What if ether3 was the master port?

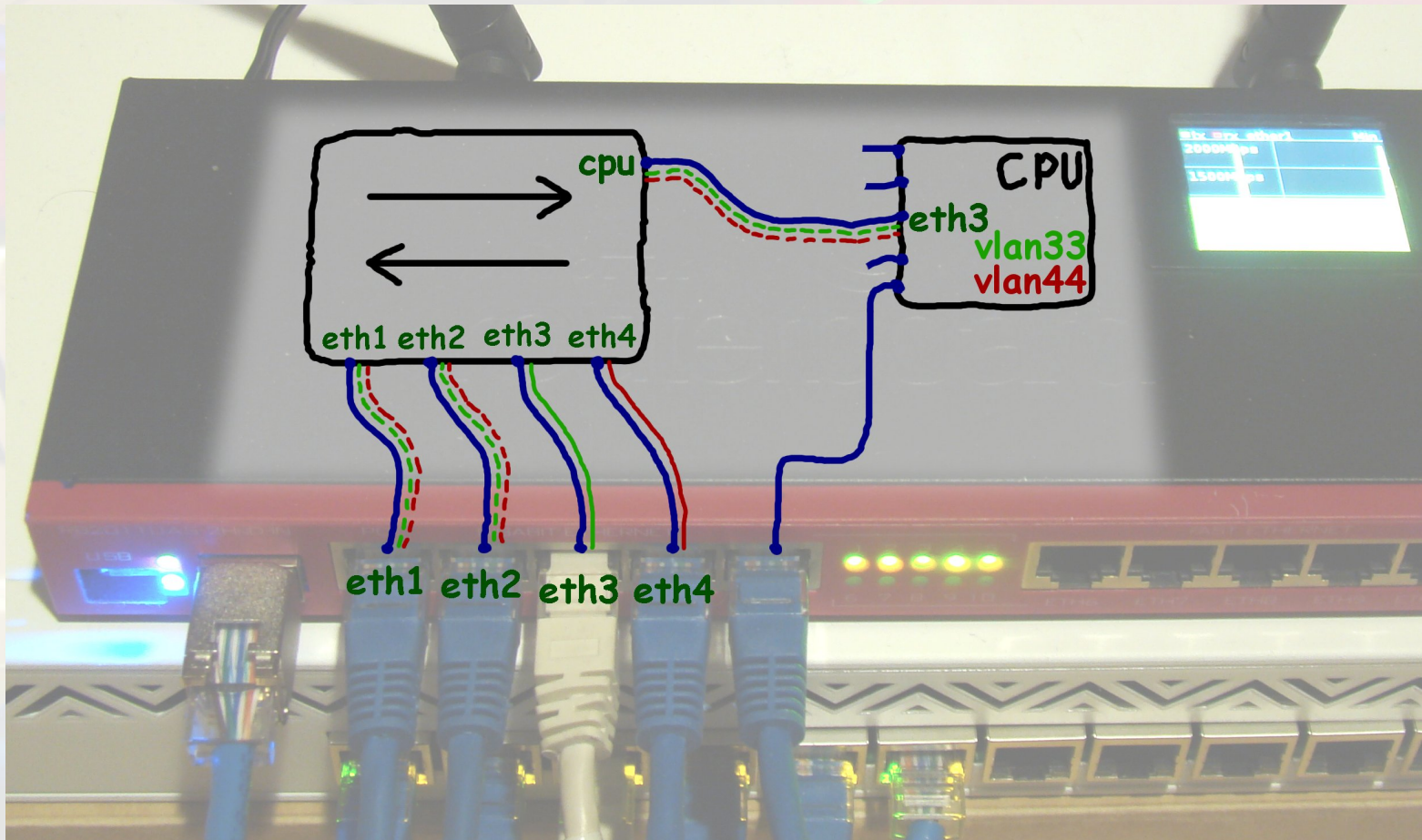

Hosts table

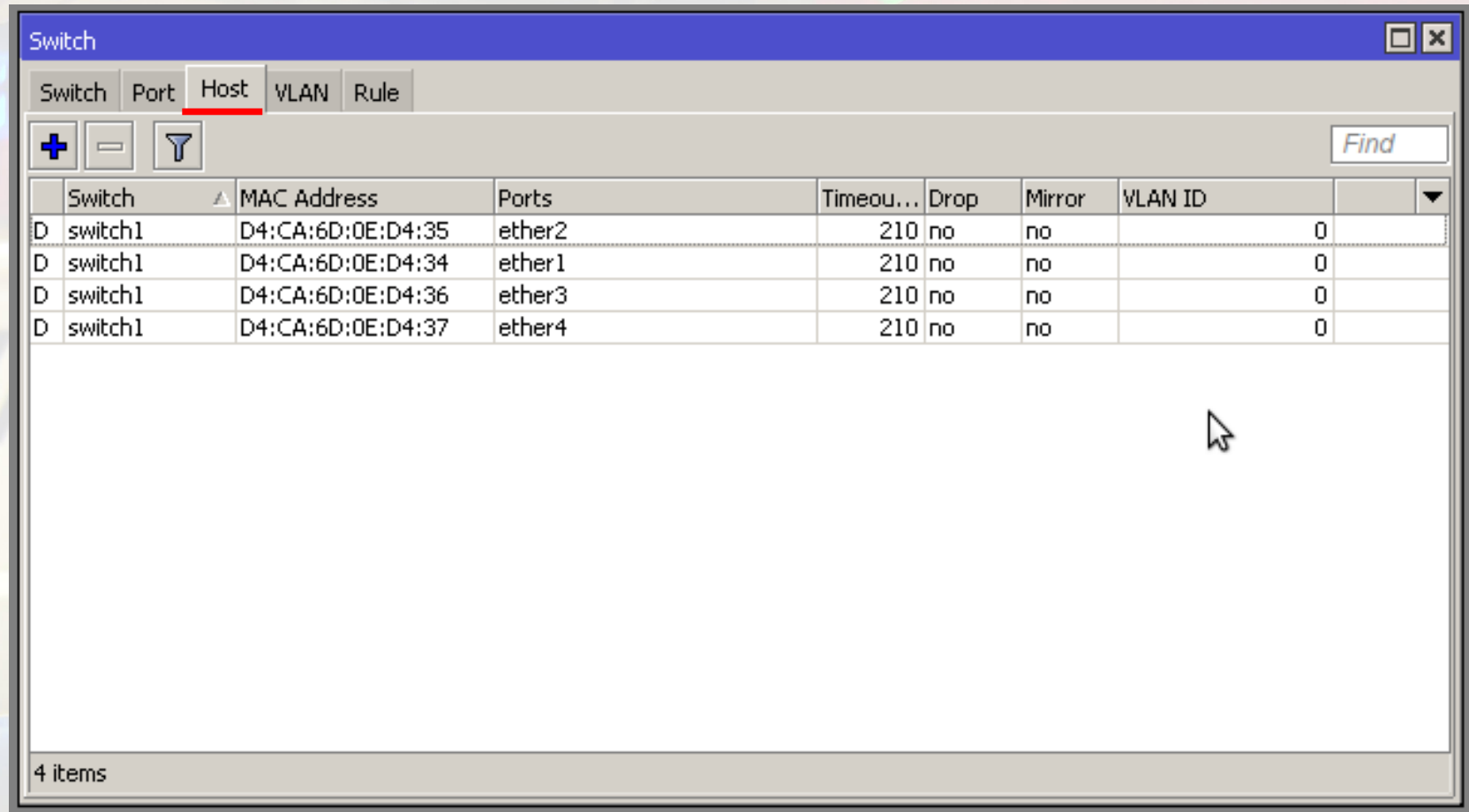

The screenshot shows a network switch configuration window titled "Switch". The "Host" tab is selected, displaying a table of host entries. The table has columns for Switch, MAC Address, Ports, Timeou..., Drop, Mirror, and VLAN ID. There are four entries listed, all for switch1 with different MAC addresses and ports (ether2, ether1, ether3, ether4). The "Timeou..." column shows a value of 210, and the "Drop" and "Mirror" columns show "no". The "VLAN ID" column shows 0 for all entries. The window also includes a "Find" search box and a status bar at the bottom indicating "4 items".

Switch	MAC Address	Ports	Timeou...	Drop	Mirror	VLAN ID
D switch1	D4:CA:6D:0E:D4:35	ether2	210	no	no	0
D switch1	D4:CA:6D:0E:D4:34	ether1	210	no	no	0
D switch1	D4:CA:6D:0E:D4:36	ether3	210	no	no	0
D switch1	D4:CA:6D:0E:D4:37	ether4	210	no	no	0

Switch chip's limitations

Feature	Atheros8327	Atheros8316	Atheros8227	Atheros7240	ICPlus175D	Other
Port Switching	yes	yes	yes	yes	yes	yes
Port Mirroring	yes	yes	yes	yes	yes	no
Host table	2048 entries	2048 entries	1024 entries	2048 entries	no	no
Vlan table	4096 entries	4096 entries	4096 entries	16 entries	no	no
Rule table	92 rules	32 rules	no	no	no	no

- Mirroring – copies of all frames (in and out) from **source** sent to **target**
- Rules – if we want to mirror or block (etc.) a selected packets

Thank you!

- I told you it was easy!

